

poli meter

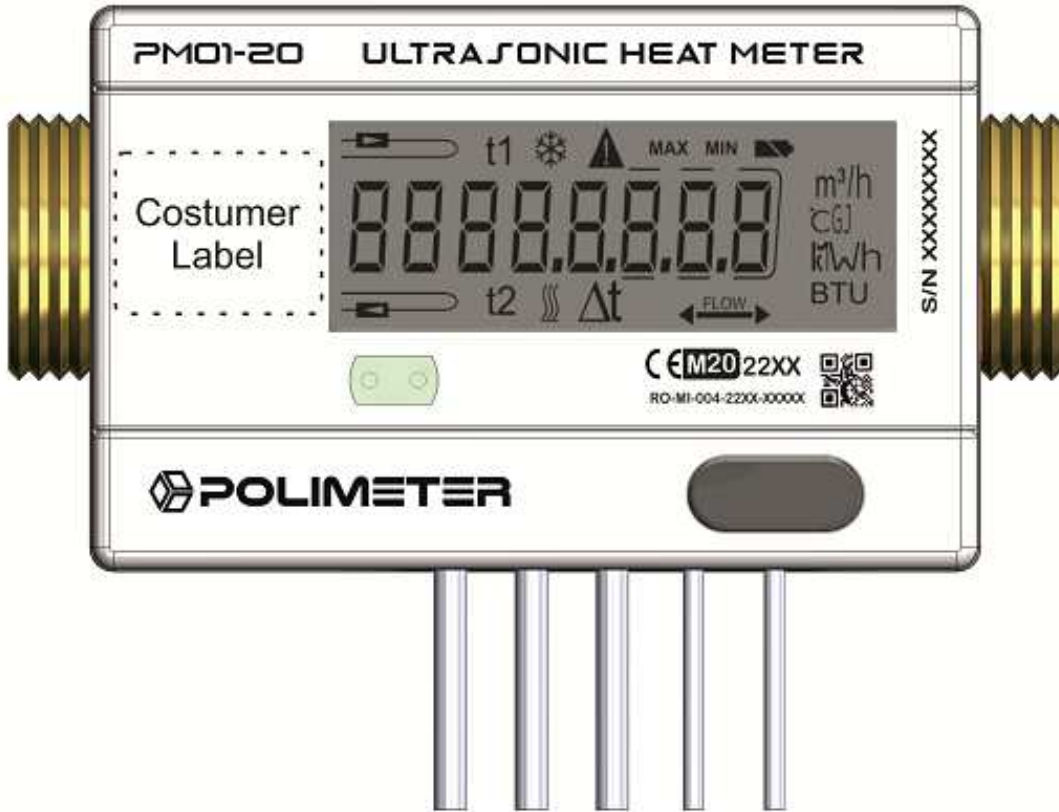

POLIMETER PM01-XX TECHNICAL DESCRIPTION



1 General description	4
1.1 Mechanical construction	5
1.2 Seals	6
2. Technical data	9
2.1 Electrical data	10
2.2 Mechanical data	11
2.3 Material	12
2.4 Accuracy	12
2.5 Type overview	13
3. Customer label	14
4. Dimensioned sketches	15
5. Pressure loss	17
5.1 Calculation of pressure loss	17
6. Installation	18
6.1 Installation angle of PM01	19
6.2 Straight inlet	20
6.3 Position of calculator	22
6.4 Mounting in inlet or outlet pipe	22
See 7.3.1 Installation type inlet and outlet	23
6.5 EMC conditions	24
6.6 Climatic conditions	24
7 Calculator functions	25
7.1 Measuring sequences	25
7.2 Energy calculation	26
7.3 Application types	28
7.4 Temperature measurement	28
7.5 ERROR codes	29
7.6 ERROR code types	29
7.7 Data Storage	30
8. Display functions	30
8.1 USER MENU	30
8.2 Historical loop	31
8.3 Log loop	31
8.4 Data loop	31
8.5 Errors loop	32

8.6 Technical loop	32
8.8 TEST loop.....	35
9 Flow sensor	35
9.1 Ultrasonic heat meters	35
9.2 Principles.....	35
9.3 Transient time method	36
9.4 Signal paths	37
9.5 Flow limits	37
9.6 Flow Sensor Data	38
10 Temperature sensors	39
10.1 Temperature sensor data	40
10.2 Sensor types	41
10.3 Coupling for direct sensor	42
10.4 Using temperature sensors as pocket sensors.....	44
11. Built-in A-cell lithium battery	45
12 Communication.....	46
12.1 Wired M-Bus	46
12.2 Sample Telegram long frame for M-bus Communication:.....	46
13. Meter Tools Software	49

1 General description

PM01-XX is the combine type measuring instrument which based on ultrasonic measuring principle. It is a measuring device which can be used in hybrid system based heating and cooling systems. It uses water as an energy carrier and precisely calculates the flow rate of the water by sending sound waves in the direction of the flow and reverse of water flow direction

According to EN 1434, the compact meter type and hybrid instrument consists of 3 main units which measure the heat meters has flow sensor, temperature sensor pair and calculator. After these parts are assembled and calibrated at the factory, it cannot be set parts apart, added, interchanged accepted by authorized service or unless by an accredited laboratory.

If flow sensor, calculator or sensor pair have been separated and the seals broken, the meter is no longer valid for billing purposes. Furthermore, the factory guarantee no longer applies.

Ultrasonic Measurement Method Used in Model PM01-XX Basically, the Ultrasonic Sensor pair The microprocessor technology inside the temperature sensors and the calculating unit and the compatibility of all units with one another ensure exceptional high measurement accuracy and reliability.

The Volume of Water is measured using the bi-directional ultrasonic technique based on the transitional time method, and the accuracy principle of this method has been proven.

The transmission time of the sound pulses sent in the flow direction called to "The transmission time in the flow direction", the transmission time of the sound pulses in the direction opposite to the flow direction is called to "The time of the transition in the reverse flow direction". The difference between "The transmission time in the flow direction", and "The time of the transition in the reverse flow direction". is an indication of the flow rate of the fluid.

These PT1000 platinum temperature measurement sensor pairs are manufactured in accordance with EN 60751 standard and it is assembled in the inlet and outlet of pipe. The first sensor is mounted and sealed at the production stage where the flow sensor is located, the second sensor is assembled on the ball valve by the service.

LCD screen structure of heat meters is designed by transreflective and wide screen, working temperature and high contrast by optionally backlight option. because of that The accumulated heat energy and/or cooling energy can be displayed in kWh, MWh, GJ all in the form of eight digits including fraction points and measuring unit.

Other reading options are: accumulated water consumption, operating hour counter, current temperature measurements, current flow and power readings. Furthermore, PM01 can display loggings, target day data, error hour counter, max. flow, max. power, information code and current date/time.

In heat meters can be use ER14505 and ER18505 battery options. ER14505 battery has 2600mAh of capacity and lifetime of heatmeter is 5-6 years. ER18505 battery has 4000mAh of capacity and lifetime of heatmeter 10-12 years. these are normal working modes values.

PM01-XX compatible to european standarts Auto meter reading systems

In designing PM01-XX great importance has been attached to user comfort and compact external measurements, which makes it suitable for a wide range of applications.

This technical description has been written with a view to enabling operations managers, meter installers, consulting engineers and distributors to utilize all functions comprised in PM01-XX. Furthermore, the description is targeted at laboratories performing tests and verification.

1.1 Mechanical construction

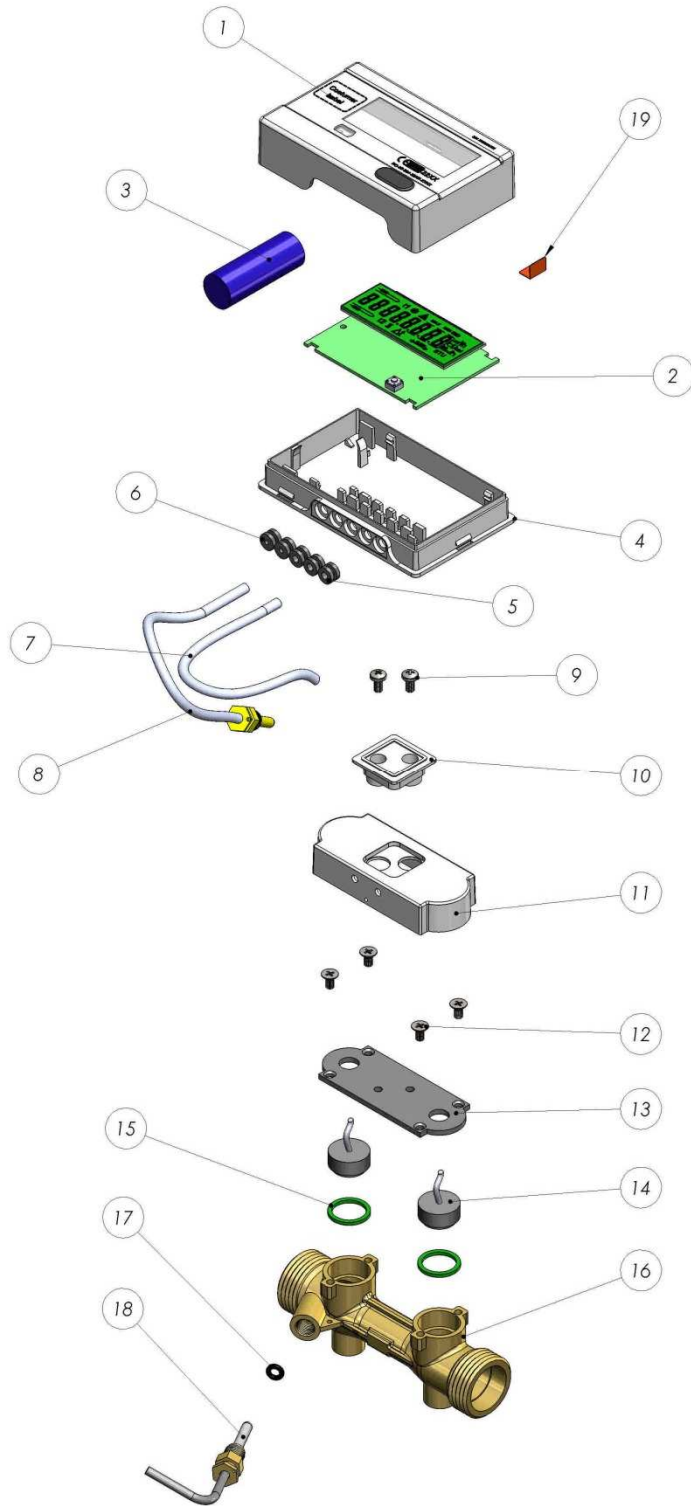

Part Number	Description
1	Pcb Top cover
2	Pcb
3	Battery
4	Pcb Bottom body
5	ø 2.5 cable seal
6	ø 4 cable seals
7	M-BUS cable
8	PT1000 Thermocouple 1
9	Slider connecting screw
10	Body sled connection
11	Transducer top cover
12	Sheet metal connection screw
13	Transducer top plate
14	Transducer sensor
15	Transducer oring
16	Brass Body
17	Thermocouple oring
18	Pt1000 Thermocouple 2
19	Seal labels

Note: All plastic part of meter can be produced by customer's color option.

1.2 Seals

Seal Plan and locking system of PM01-XX model heat meter is shown in the below side; the first sensor and calculator seal out during the manufacturing on the brass body and the second temperature sensor seal out during assembly.

IMPORTANT: If seals are broken, the counter is no longer eligible for billing. For this reason, the court can only be opened by a competent laboratory with the authority to re-verify the counter after it has been approved.

METROLOGICAL SEAL 1 Manufacturer sealing place

Calculator seal

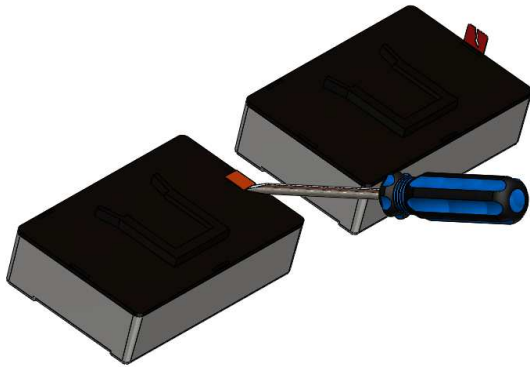

The unlock calculator parts

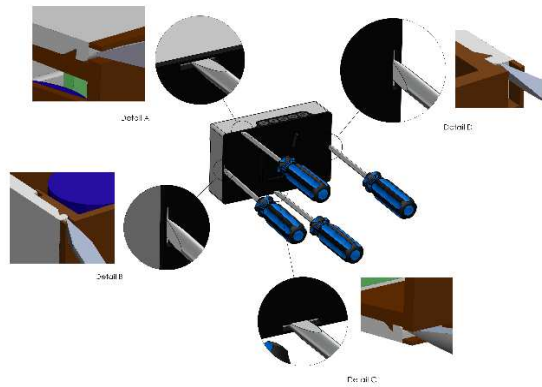

METROLOGICAL SEAL 2
Manufacturer sealing place

Brass body seal

Brass body seal

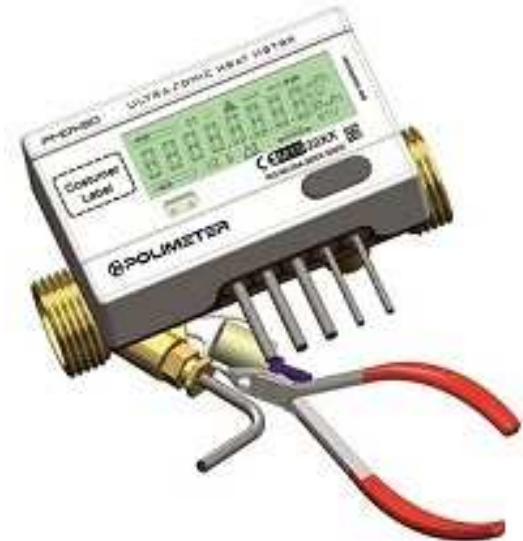
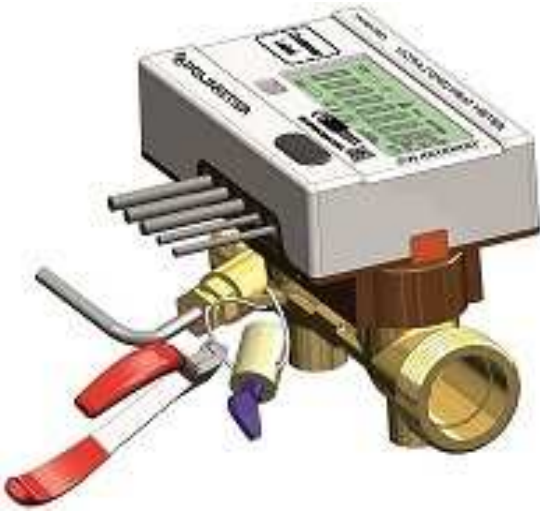

METROLOGICAL SEAL 3
Service seal place

Ball valve seal

Ball valve seal

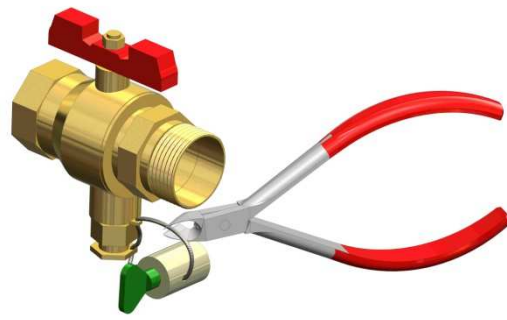
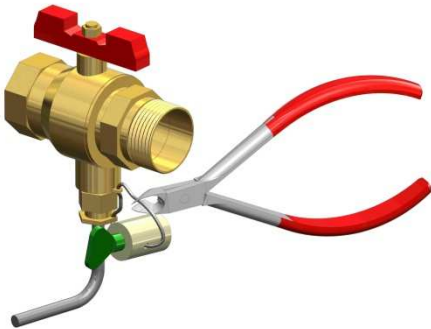

METROLOGICAL SEAL 4

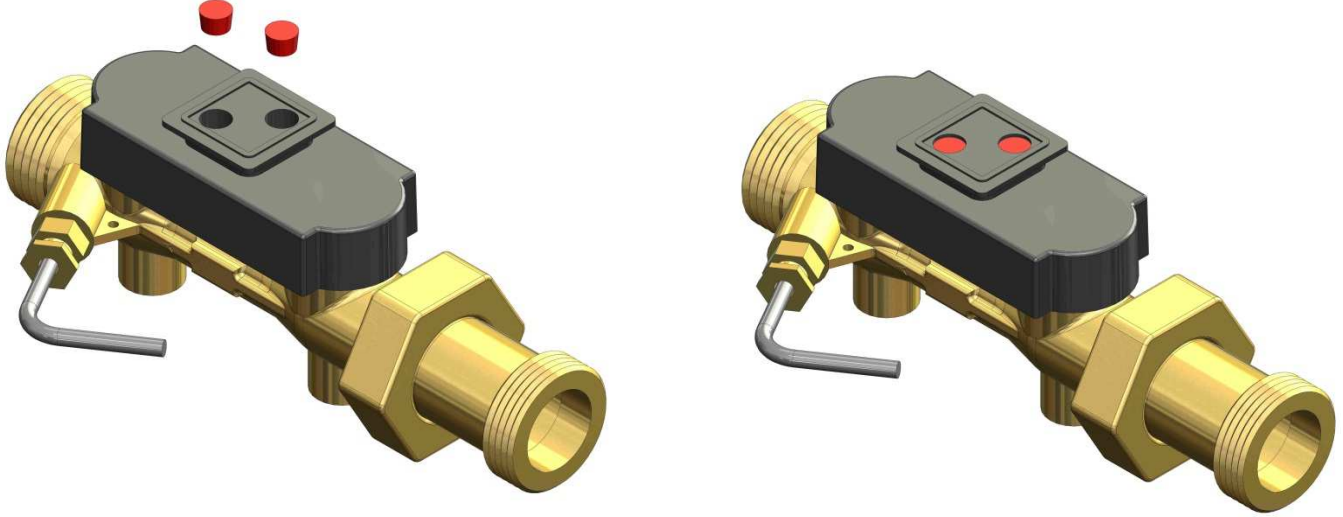

2. Technical data

Standards EN 1434:2015
 EU directives Measuring Instruments Directive, Low Voltage Directive, Electro-magnetic Compatibility Directive, Pressurised equipment Directive

Temperature range θ : 5 °C...90 °C

Differential range $\Delta\theta$: 3 K...75 K / According to EN1434 - 2015

Alternative temperature ranges θ : 5 °C...90 °C / $\Delta\theta$: 3 K...75 K

θ : 2 °C...50 °C / $\Delta\theta$: 3 K...30 K

Accuracy According to EN 1434
 Temperature sensors Dry and Wet temperature sensors, Pt1000 – EN 60 751, 2-wire, hard-wired connection
 EN 1434 designation Accuracy class 2 / Environmental class A
 MID designation Mechanical environment: Class M1
 Electromagnetic environment: Class E1
 Closed location (indoors), 5...55 °C

Table 1	Nom. flow	Max. flow	Min. Flow	Min. Cut-off	Pressure loss Δp @ q_p	Threaded connection on meter	Length
			100:1				
Type number	q_p [m ³ /h]	q_s [m ³ /h]	q_i [m ³ /h]	[l/h]	[bar]		[mm]
PM01 X-XX	1.5 0.6	3.0 1.2	0,015 0,006	3	0,25	G¾B	110
PM01 X-XX	1,5	3,0	15	3	0,25	G¾B	110
PM01 X-XX	2,5	5,0	25	5	0,25	G1B	130
PM01 X-XX	3,5	7,0	35	35	0,25	G1 1/4B	160
PM01 X-XX	6,0	12,0	60	60	0,25	G1 2/4B	180
PM01 X-XX	10,0	20,0	100	100	0,25	G2B	200

2.1 Electrical data

Calculator data

Display	LCD – (8) digits with digit height 6 mm
Resolution	9999,999 – 99999,99 – 999999,9 – 9999999
Energy units	MWh – kWh – GJ- °C
Data logger (Eeprom)	Past 24 month
Clock/calendar	Clock, calendar, leap year compensation, target date
Data communication	Compatible To AMR / M-BUS system , Optical system
Wired M-Bus	Protocol according to EN 13757-3, 300 and 2400 Baud communication speed with automatic baud rate detection. Current consumption 1 unit load (1.5 mA). 1.5 m fixed 2-wire cable. Polarity independent.
Power of temperature sensors	< 0.5 μ W RMS
Supply voltage	3.6 VDC \pm 0.1 VDC
EMC data	Fulfils EN 1434:2015 class A (MID class E1)

Temperature measurement

2-Wire Pt1000	T1 Inlet temperature	T2 Outlet temperature	$\Delta\theta$ (T1-T2) Heat metering	$\Delta\theta$ (T2-T1) Cooling metering
Measuring range	0.00...105.00 °C	0.00...105.00 °C	0.01...105.00 K	0.01...105.00 K

Battery Characteristics

PM01-XX Series can be fitted with battery of **EVE**

Manufacturer	EVE
Type	ER18505 ; 14505

Technology	Lithium
Size	A
Capacity	3600 mAh
Content	1 pc(s)

Battery	ER14505	ER18505
---------	---------	---------

Nominal capacity	2.7 Ah	4.0 Ah
Nominal voltage	3.6V	3.6V
Maximum recommended continuous current	40mA (To get 50% of the nominal capacity at +25 C with 2.0V cut off.)	130mA (To get 50% of the nominal capacity at +25 C with 2.0V cut off.)
Pulse capability		Typically up the 180mA
Storage life be stored in a dry and cool place at 15°C	6 years	10 years
Operating temperature range	-60°C/+85°C	-55°C / +85°C
Typical weight	19g	28g
tBAT < 30 °C	6 years	10 years
tBAT < 45 °C	5 years	9 years

Important: Change of battery on PM01 X XX may only be performed by a FNF service centre

2.2 Mechanical data

Environmental class

Fulfils EN 1434 class A (MID class E1) and class M1

	Protection class	Ambient temperature	Environmental class	
Calculator	IP65	5...55 °C	Non-condensing	Indoors (closed position)
Flow sensor and sensor pair	IP68		Condensing	

Medium temperatures

Heat/cooling meters PM01-H	2...105 °C	At medium temperatures above 90 °C in the flow sensor
Cooling meters PM01-	2... 50 °C	
Medium in flow sensor	Water	
Storage temperature	-25...60 °C (drained flow sensor)	
Pressure stage (with thread)	PN16	
Weight	From 0.7 to 1.1 kg depending on flow meter size and extension piece	
Flow sensor cable	1.2 m (undemountable cable)	
Temperature sensor cables	1.5 m (undemountable cables)	

2.3 Material

Mechanical Spec	
Top cover of Calculator	ABS, Thermoplastic, ABSPC with TPE gaskets (thermoplastic elastomer)
Bottom cover of Calculator	ABS, Thermoplastic, ABSPC with TPE gaskets (thermoplastic elastomer)
Flow Body	Brass(MS58), Stainless steel, W.no. 1.4404, chrome rod for Ult. mirrors
Lens in front of LCD	PMMA
Flow Sensors	Thermoplastic composit
Flow sensor cables Temperature cables M-Bus cables	Silicone cable with inner Teflon insulation

2.4 Accuracy

Heat meter components	MPE according to EN 1434-1:2015
Flow sensor	$E_f = \pm (2 + 0.02 q_p/q) \%$
Calculator	$E_c = \pm (0.5 + \Delta\theta \text{ min}/\Delta\theta) \%$
Sensor pair	$E_t = \pm (0.5 + 3 \Delta\theta \text{ min}/\Delta\theta) \%$

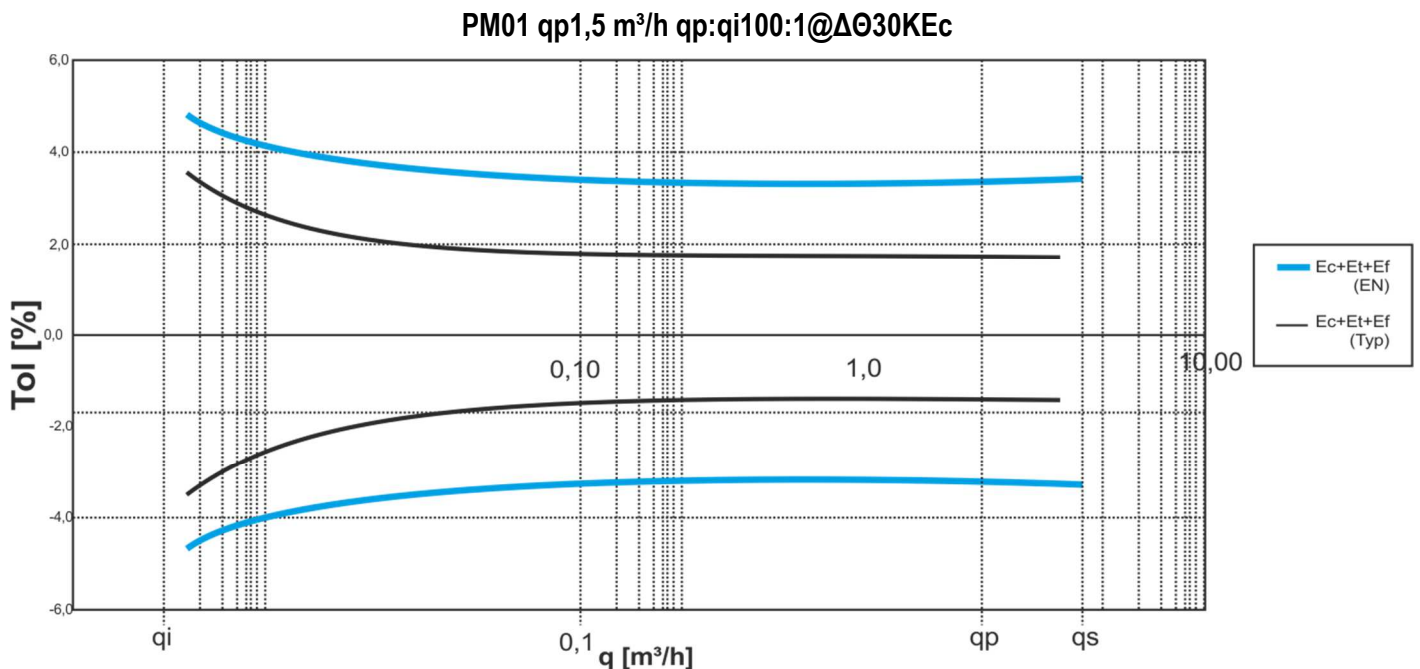

Diagram 1: Total typical accuracy of PM01 compared to EN 1434-1.

2.5 Type overview

Type PM01			X			XX	
Basic version							
Heat or cooling meter			H				
Heat&cooling meter			M				
Flow sensor qp [m ³ /h]	Connection	Length [mm]					
0.6	G ³ / ₄ B (R ¹ / ₂) DN15	110				15	
1.5	G ³ / ₄ B (R ¹ / ₂) DN15	110				15-1	
2.5	G1B (R ³ / ₄) DN20	130				20	
3.5	G1 1/4B DN25	160				25	
6	G1 2/4B DN32	180				32	
10	G2B DN40	200				40	

The flow sensors are approved for flow rate ranges qp:qi = 100:1

Example model for DN15 110mm Heating: PM01-H-15

3. Customer label

The customer label or logo with the dimensions of 25x25 mm can be designed on request at the left middle part of the front of the meter. Company logo and information fit to 25x25 mm can be added with the desired color and design using special printing machines.

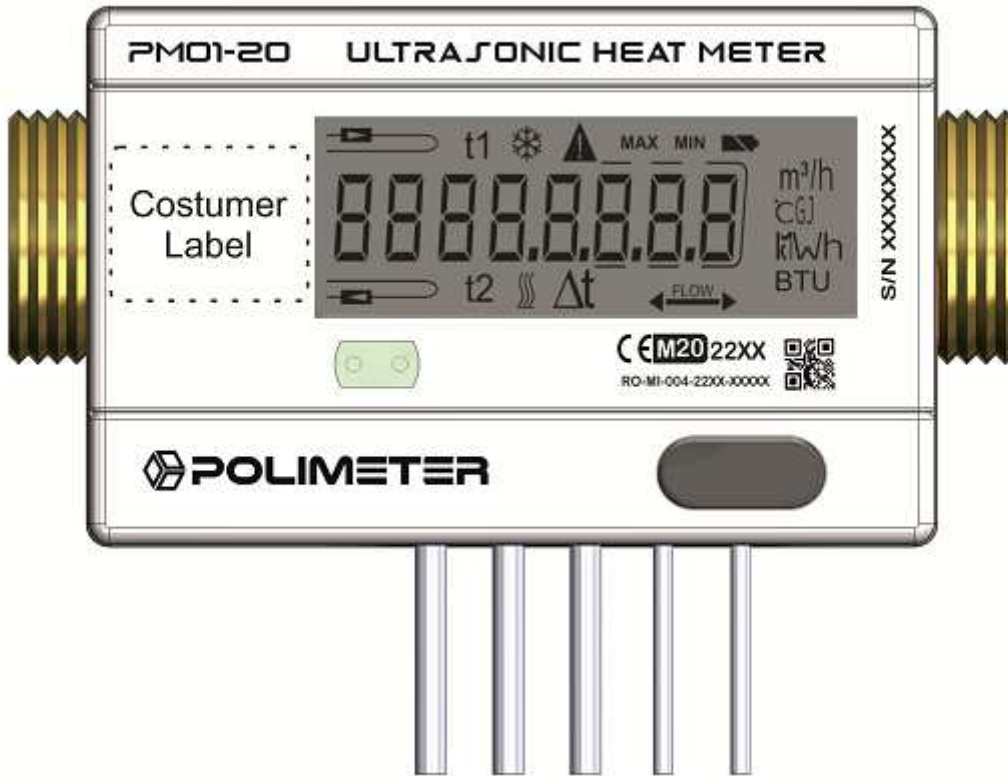

4.Dimensioned sketches

Calculator

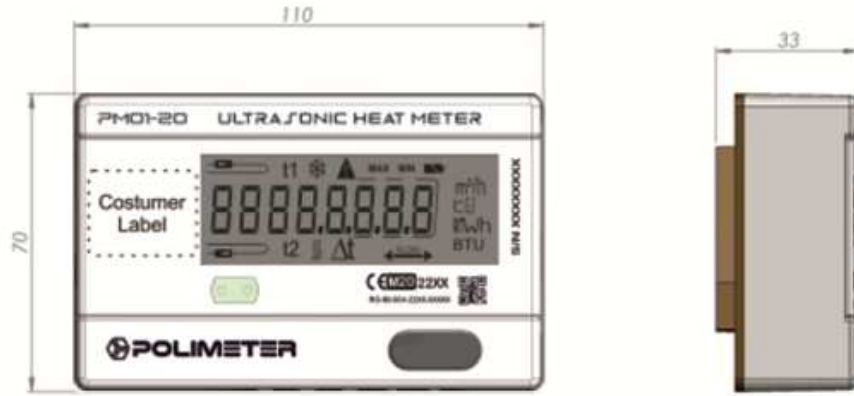

Wall-mounted calculator

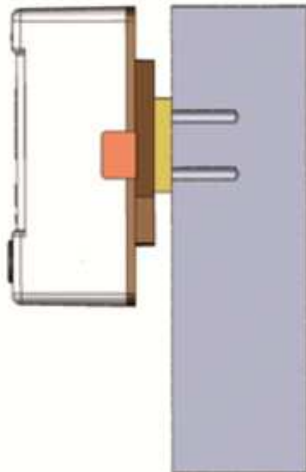

Wall fitting for calculator

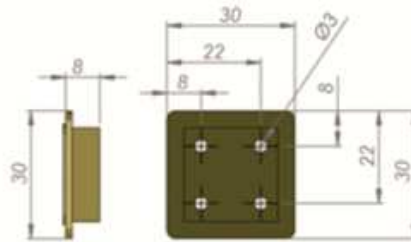

EM01 mounted on flow sensor

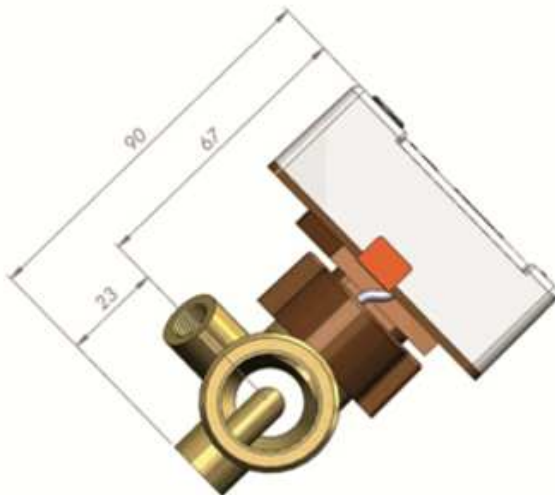

All measurements in [mm]

Flow sensor

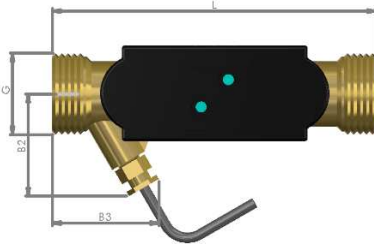
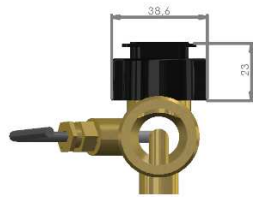
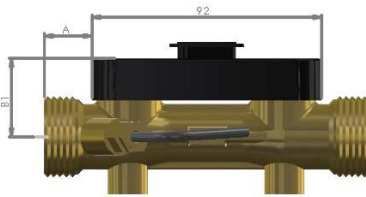
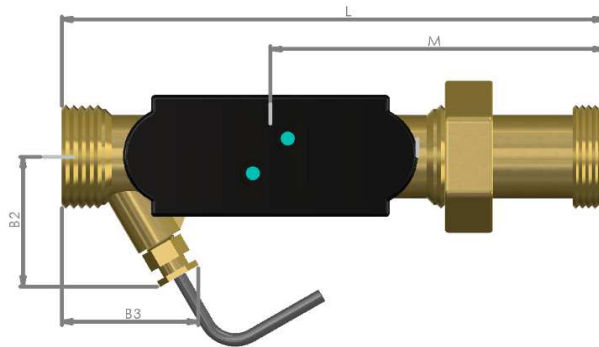
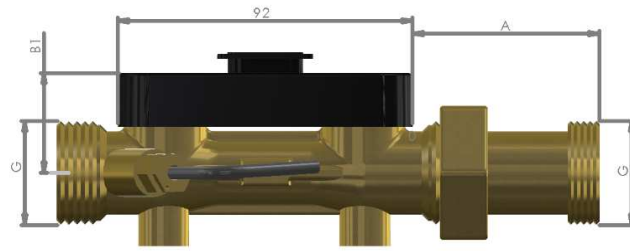

Thread	L	A	B1	B2	B3	Approx. weight [kg] *)
G ³ / ₄ B (R ¹ / ₂)	110	12	35	35	40	0.7
G1B (R ³ / ₄)	130	22	38	38	50	0.8

All measurements in [mm]

5. Pressure loss

Pressure loss in a flow sensor is stated as max. pressure loss at qp. The pressure loss should be measured with a maximum expanded uncertainty of 5 %, with a coverage factor of k = 2. The pressure loss of the meter shall not exceed 0.063 MPa (0.63 bar) at any flowrate between Q1 and Q3 inclusive

The pressure loss in a sensor increases with the square of the flow and can be stated as:

$$Q = kv \times \sqrt{\Delta p}$$

where: Q = volume flow rate [m³/h]
 kv = volume flow rate at 1 bar pressure loss [m³/h]
 Δp = pressure loss [bar]

Graph	qp [m ³ /h]	Housing	Nom. diameter[mm]	Δp @qp [bar]	Q@0.25 bar [m ³ /h]
A	0.6	G3/4B x 110 mm	DN15	0.25	2.4
A	1.5	G3/4B x 110 mm	DN15	0.25	2.4
B	2.5	G1B x 130 mm	DN20	0.25	4.1
C	3.5		DN25	0.25	
D	6.0		DN32	0.25	
E	10.0		DN40	0.25	

Table 2: Approximated pressure loss table
 Δp PM01

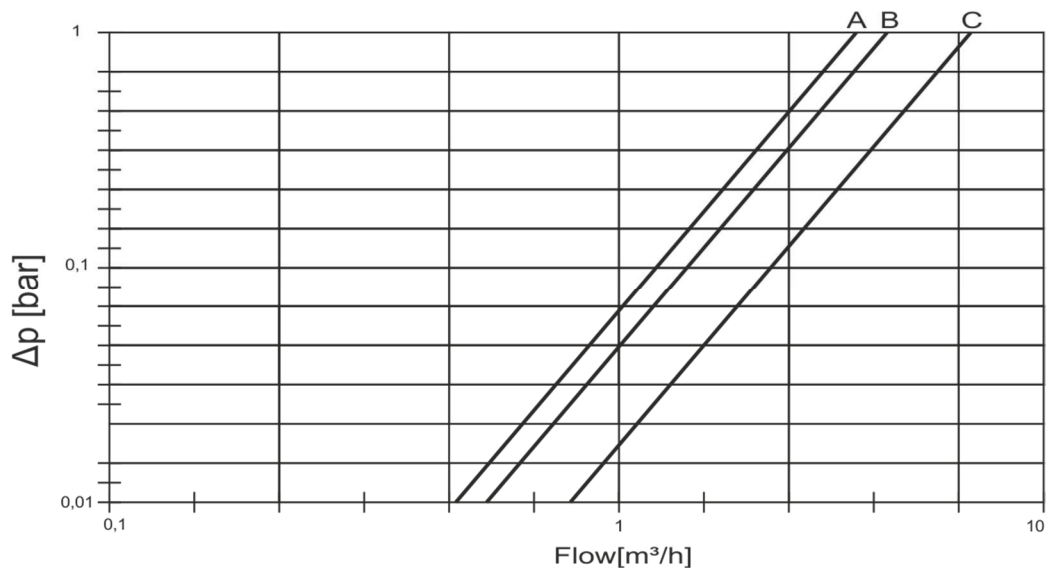

Diagram 2: Pressure loss graphs

5.1 Calculation of pressure loss

The pressure loss at a given water flow can be calculated as: $\Delta p = (Q/kv)^2$.

Example: a qp 1.5 meter with a current flow of 0.5 m³/h: $\Delta p = (0.5/1.5)^2 = 0.11$ bar

6. Installation

The valves of the fittings must be closed before installation. The meter must be correctly mounted to the inlet or outlet of the installation. Correct mounting of flow sensor in inlet or outlet appears from the display. During the installation of the meter original gasket and fittings must be used specified by the company. The installation of the meter should be in the direction of the arrow shown on the screen.



Example of display reading if the meter is configured for "flow sensor in inlet pipe"



Example of display reading if the meter is configured for "flow sensor in outlet pipe"

When the installation has been completed, water flow can be turned on. The valve on the inlet side of the flow sensor must be opened first. The flow sensor must not be exposed to lower pressure than the ambient pressure (vacuum). In order to prevent cavitation the operating pressure at the flow sensor must be min. 1 bar at qp and min. 2 bar at qs. This applies to temperatures up to approx. 80 °C.

The meter must not be under any mechanical stress when installed in the pipe. The meter must be protected against pressure shocks in the pipe. The humidity of the mounting environment shall not exceed 85% (without condensation). Protection class IP65 allows short-term submergence, provided that all cable unions have been correctly mounted and that the plastic cover has been properly fastened. Make sure the meter is installed sufficiently far away from possible sources of electromagnetic interference (switches, electric motors, fluorescent lamps, etc.).

All control cables must be drawn separately and not parallel to e.g. power cables or other cables with the risk of inducing electromagnetic interference. There must be a distance of min. 25cm between signal cables and other installations.

If two or more meters are to be installed shall be in parallel, the axis-center distance between two meters shall be at least 135mm minimum.

Prior to installation of the flow sensor, the pipe shall be thoroughly flushed out, and any dirty, stone alike items must be removed from the pipe. Cavitation in the system must be avoided. If a risk of frost exists, empty the system and, if necessary, remove the meter. If the water is soiled, fit the strainer in the pipe before the meter.

Permissible operating conditions

Ambient temperature:	5...55 °C (indoors). Max. 30 °C for optimum battery lifetime.
Temperature of medium:	2...130 °C with calculator mounted on a wall 15...90 °C with calculator mounted on flow sensor
System pressure:	1...16 bar or 1...25 bar depending on the meter's marking

Service

the meter should not be mounted with welding and freezing system or glue for easy separation of the meter when service or when it is in need of repair. In order to facilitate replacement of the meter, closing valves should be mounted on both sides of the meter.

Under normal operating conditions no pipe strainer is required in front of the meter.

6.1 Installation angle of PM01-XX

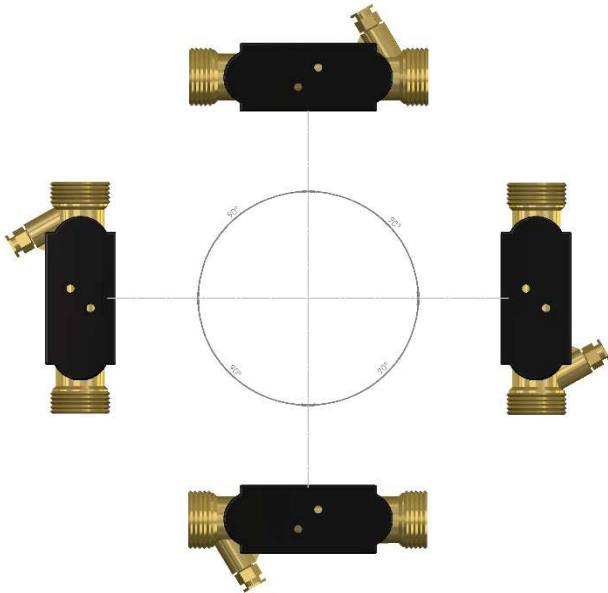

PM01-XX can be installed horizontally, vertically, or at an angle.

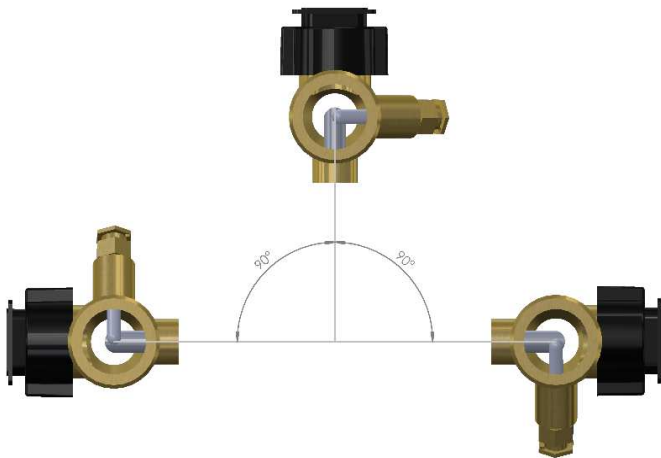

Important!
PM01-XX can be mounted at 0 ° (horizontal) and in all angles down to 90 ° (vertical) in respect to the pipe axis.

6.2 Straight inlet

PM01-XX requires neither straight inlet nor straight outlet in order to fulfil the Measuring Instruments Directive (MID) and EN 1434 . A straight inlet section will only be necessary in case of heavy flow disturbances before the meter. We recommend you to follow the guidelines of CEN CR 13582.

Optimal position can be obtained if you take the below-mentioned installation methods into consideration:

	<p>A Recommended flow sensor position</p> <p>B Recommended flow sensor position</p> <p>C Unacceptable position due to risk of air build-up</p> <p>D Acceptable position in closed systems</p>
	<p>E A flow sensor should not be placed immediately after a valve, except for block valves, which must be fully open when not used for blocking</p> <p>F A flow sensor ought not be placed directly before (suction side) or directly after (outlet side) a pump</p> <p>G A flow sensor should not to be placed close to a two-level double bend.</p>

For general information concerning installation see CEN report *DS/CEN/CR 13582, Heat meter installation*. Instructions in selection, installation and use of heat meters. Mounting of flow sensor Consider the dimensions of the heat meter, and the distance with surroundings, minimum 3 cm free space. Straight sections of 10×DN before and 5×DN after the meter are recommended, to homogenize the flowrate of water. The meter is to be installed so that the direction of the arrow on the meter housing corresponds to the direction of flow. Avoid the collection of air bubbles in the meter during the installation process.

Installation examples:

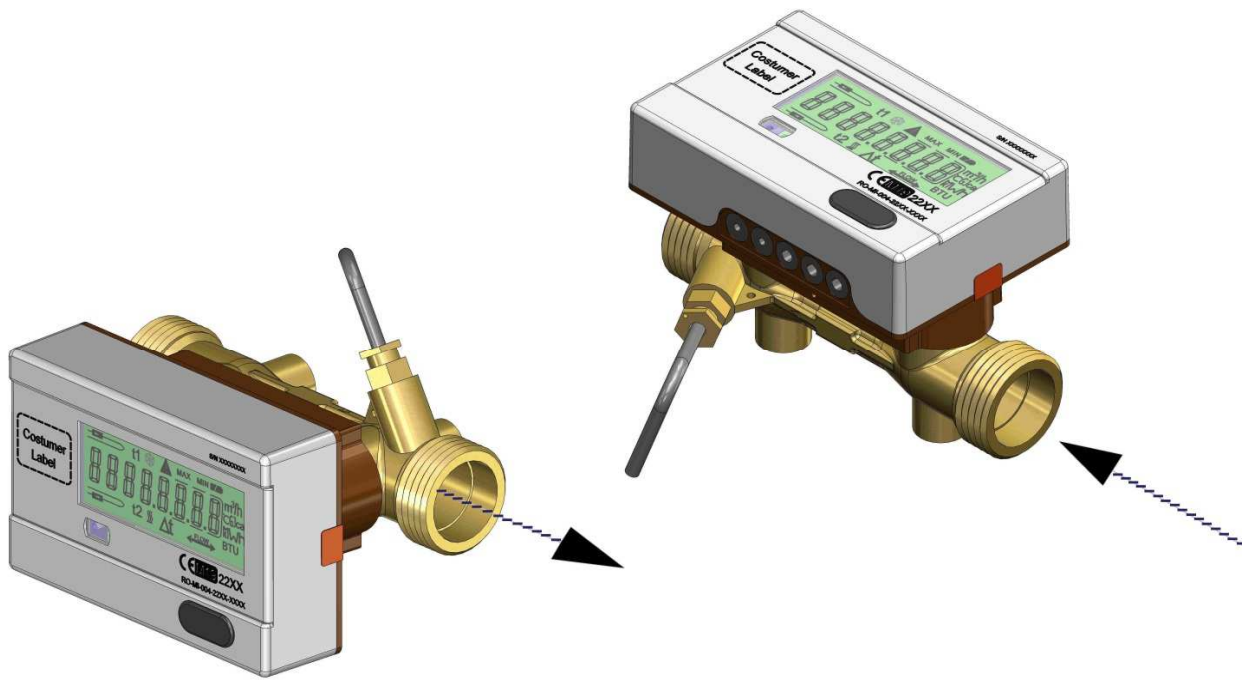
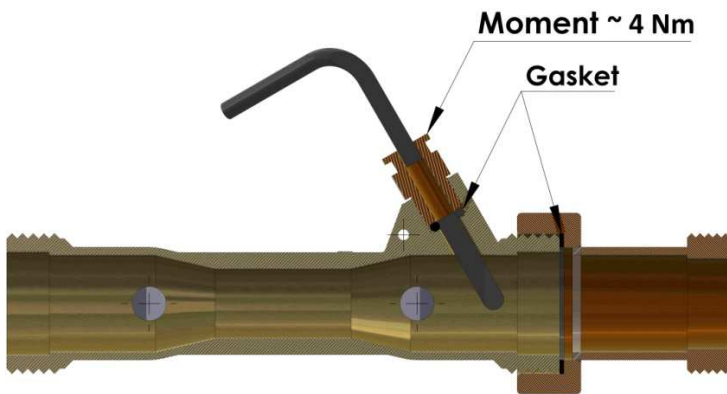
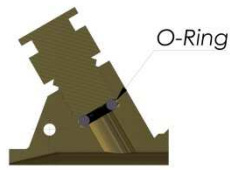

Figure 4: Threaded meter



Mounting of couplings as well as temperature sensor mounted in PM01-XX flow sensor. Flow and temperature sensor can be installed in both PN16 and PN25 installations. Enclosed couplings, if any, are only intended for PN16. Suitable PN25 couplings must be used for PN25 installations.



A blind plug, which can be used if the temperature sensor is removed from the flow sensor and e.g. installed in a sensor pocket, is available.

6.3 Position of calculator

If the flow sensor is mounted in a humid or condensing environment, the calculator must be placed in a higher position than the flow sensor.

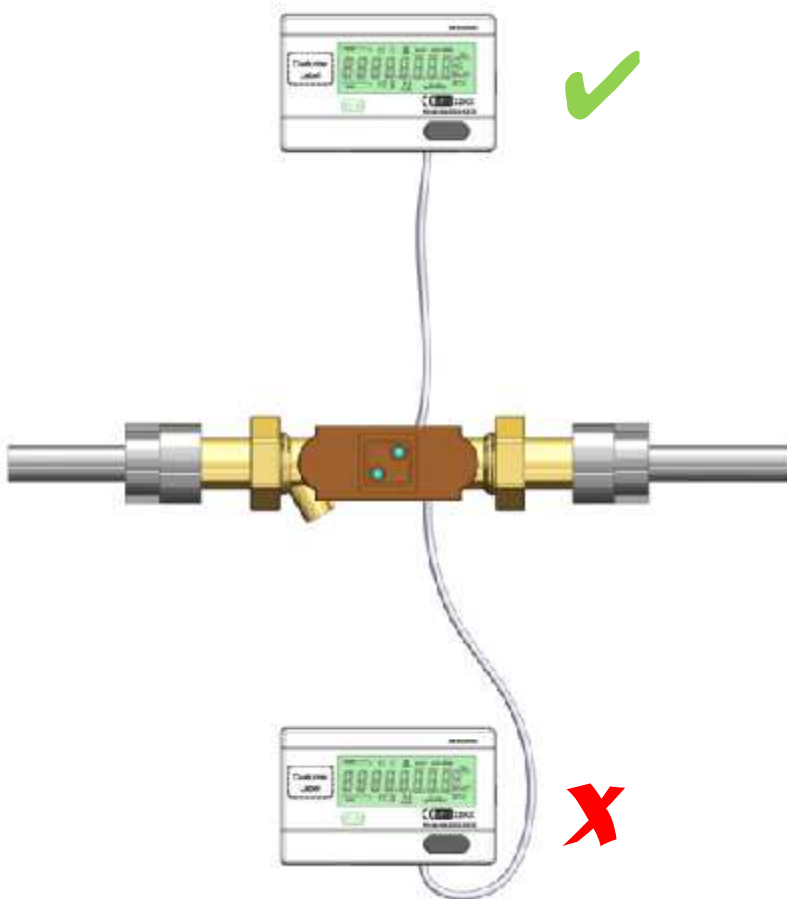

6.4 Mounting in inlet or outlet pipe

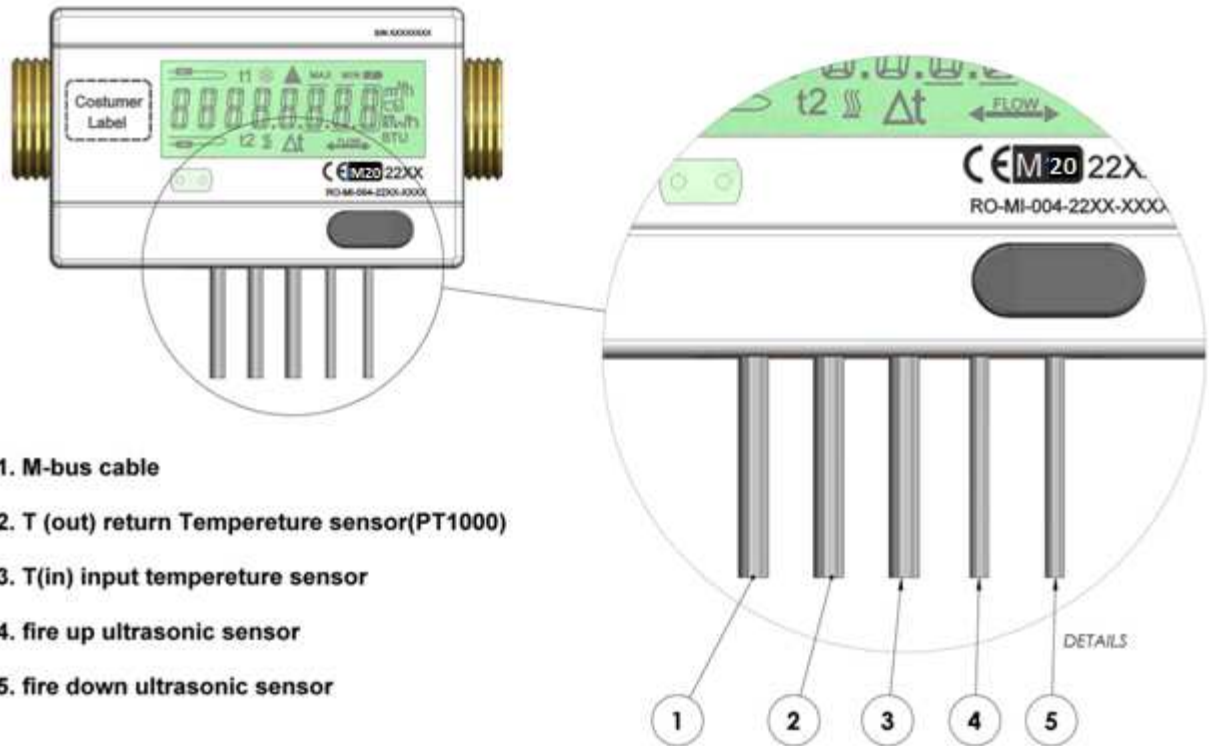

1. M-bus cable
2. T (out) return Temperature sensor(PT1000)
3. T(in) input temperature sensor
4. fire up ultrasonic sensor
5. fire down ultrasonic sensor

There are 5 cables . One cable is connected to the M-bus . The other two cables are connected to the flow sensor . The other two cables are temperature sensors, connected to the meter. If one temperature sensor is mounted in the flow sensor, this sensor is called Tm and the other sensor is called To.

There are two type temperature sensor , hot water temperature sensor (red color) ,intallation to inlet, And cold water temperature sensor (blue color), It is installed on outlet . It is placed on meter as a default option. But at cooling or heating meter type we can change place of temperature sensor type as depend on instaliation type

See 7.3.1 Installation type inlet and outled

6.5 EMC conditions

PM01-XX has designed according to EN1434 and CE marked . it can be mounted in domestic and industrial environments due to Class E2 and Class A1.

All control cables must be drawn separately and not parallel to e.g. power cables or other cables with the risk of inducing electromagnetic interference. There must be a distance of min. 25 cm between signal cables and other installations.

6.6 Climatic conditions

The PM01-XX is designed for indoor installation in non-condensing environments with an ambient temperature of 5-55 C and for optimum battery life 30 c.

IP codes define the ability of an object to resist dust and water. The scale in this instance is from 4 to 6 . The first number indicates dust resistance, the second is water resistance. For example, IP44 indicates dust resistant, splash resistant; while IP65 means dust-proof and wash-down capable. Number of 6 means Totally protected against dust and defatation of 5 is Protected against low pressure jets if water from all directions - limited ingress permitted. Protected from low pressure water jets from any direction, limited ingress protection.

Protection class IP68 for the flow sensor allows permanent condensation and submergence.

7 Calculator functions

7.1 Measuring sequences

The meters working mode can change in the tech menu (inside to 06-04 with long press to button) or with the meters tools software. The heat meters measurement periods depend meters working modes with considering kept to long battery life

Note:

TP_Flow = Time Period of measurment Flow

TP_Temp = Time Period of measurment Temperetures

TP_Calc = sample count for flow measurment

Example : TP_Flow : 2sec; TP_Temp : 10sec ; TP_Calc : 10 sample

the meters starts to flow measurment every 2 sec and save to sequence 10 sample that is during totally (2sec x 10sample = 20 sec) after it calculate energy and the meter continue temperature measurment every 10 sec

"SET-1" mode- transportation mode

All meters set up in "SET 1 " mode while is left from factory. "SET 1 " means 'transportation mode'. It aims to keep the shelf life of battery longer. after installation and the meter inside passed 10lt water the meter change the working mode to normal mode with automaticly

TP_Flow = 30sec

TP_Temp = 60sec

TP_Calc = 5 sample

"SET-2" mode- normal

"SET-2" mode means normal mode. "SET 2" mode is meant for regular meter operation. After the meter has been installed ,the meter switches to automatic set2 mode after the water reaches the 10 lt flow rate. And never return back to set 1 mode . Until water reaches 10 Lt the meter will run in setup mode. In "SET 2" mode

TP_Flow = 4sec

TP_Temp = 10sec

TP_Calc = 10 sample

"SET-3 " mode-fast response mode

"SET 3" mode means fast mode. it is used for industrial purposes . It is used where need to quick response and calculate faster of calculator .

TP_Flow = 1sec

TP_Temp = 2sec

TP_Calc = 5 sample

"SET-4" Test mode"(initial verification test mode)

The Test mode gives a high accuracy measurement results during the verification test time. on this mode accuracy for energy shown as 0.001 precision and for volume results as 0.001. Users can pass to the Test mode by long press button in menu 06-04 or use meter tools software or by press button in Test menu. When user gets in Test menu, meter switch to the Test mode automatically and when change the menu meter return back to the next menu.

TP_Flow = 2sec

TP_Temp = 5sec

TP_Calc = 10 sample

7.2 Energy calculation

PM 01-XX calculates energy as specified in EN1434-1:2015 . Heat transmitted to or from a body of liquid can be determined from knowledge of its mass, specific heat capacity and change in temperature. In a heat meter, the rate of change of enthalpy between the flow and return through a heat exchanger is integrated with respect to time. The equation for its operation is as follows:

$$Q = \int_{t_0}^{t_1} q_m \Delta h dt$$

If the instrument determines the volume instead of the mass, its equation becomes:

$$Q = \int_{V_0}^{V_1} k \Delta \Theta dV$$

Q is the quantity of heat given up;

q_m - is the mass flow rate of the heat-conveying liquid passing through the heat meter;

Δh - is the difference between the specific enthalpies of the heat-conveying liquid at the flow and return temperatures of the heat-exchange circuit;

t - is time.

V - is the volume of liquid passed;

k - called the heat coefficient, is a function of the properties of the heat-conveying liquid at the relevant temperatures and pressure;

$\Delta \Theta$ - is the temperature difference between the flow and return of the heat exchange circuit.

The meter always calculates energy in [Wh], and then converts the value to the selected measuring unit.

$$k = \frac{1}{v} \frac{h_f - h_r}{\theta_f - \theta_r} \quad v(\pi, \tau) \frac{\rho}{RT} = \pi \gamma_\pi \quad \pi = p / p^* \text{ with } p^* = 16.53 \text{ MPa}$$

$$\gamma_\pi = \sum_{i=1}^{34} -n_i I_i (7.1 - \pi)^{I_i - 1} \quad \text{For the figures of } n_i, I_i \text{ and } J_i \text{ see Table.}$$

$$\tau = T^* / T \text{ and } T^* = 1386 \text{ K}$$

$$\gamma_\tau = \sum_{i=1}^{34} n_i (7.1 - \pi)^{I_i} J_i (\tau - 1.222)^{J_i - 1}$$

Example : $dV = 100 \text{ Kg (water)}$

	Flow position	Return position
Temperature	$\theta = 70$	$\theta = 40$
Specific volume in (m ³ /kg)	$0,102204 \cdot 10^{-2}$	$0.100370 \cdot 10^{-2}$
Specific enthalpyflow in (kJ/kg)	$0,294301 \cdot 10^3$	$0.294301 \cdot 10^3$
Specific enthalpyreturn in (kJ/kg)	$0,127200 \cdot 10^3$	$0.127200 \cdot 10^3$
Heat coefficient in (MJ/(m ³ K))	4,0874	4,1621

$$Q = \int_{V_0}^{V_1} k \Delta \theta dV = 4,1621 \times 40 \times 100 / 3600 = 4,6245 \text{ kW/h}$$

E [Wh] =	$V \times \Delta \theta \times k \times 1,000$
E [kWh] =	$E [\text{Wh}] / 1,000$
E [MWh] =	$E [\text{Wh}] / 1,000,000$
E [GJ] =	$E [\text{Wh}] / 277,780$

Both in the display and during data reading each energy type is uniquely defined, e.g.

Heat energy: $E1 = V1(Th-Tc)k$



Cooling energy: $E3 = V1(Th-Tc)k$



7.3 Application types

7.3.1 Installation type inlet and outlet

T_{in} : RED labels temperature sensors
 T_{out} : Blue labels temperature sensors

Q_{hc} : start of the heat energy specific Temperature
 Q_{ch} : Start of the Cooling specific Temperature

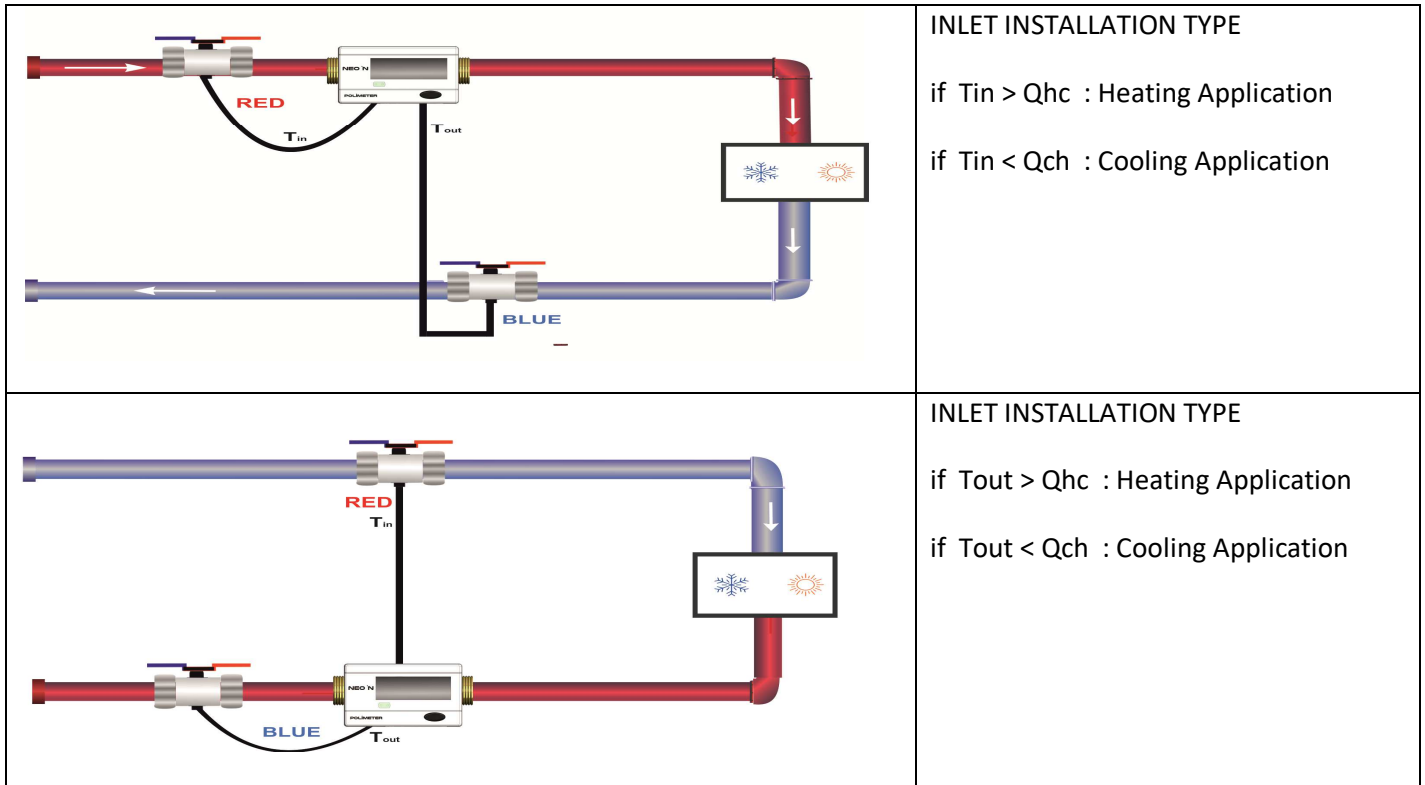

7.4 Temperature measurement

Inlet and outlet temperatures are measured by means of an accurately matched Pt1000 sensor pair. During each temperature measurement PM01-XX sends measuring current through each sensor





The accuracy of measurement is sensitive to the temperature sensor installation, including the temperature sensor size, pipeline diameter and sensor depth.

To ensure heat meter accuracy only used original components supplied by FNF and according to instructions outlined here.

7.5 ERROR codes

If any error occurs in the measuring system or in the installation, these errors are indicated by the flashing info code in the PM01-XX display. The info code continues to flash as long as the error persists. When the error disappears, the info code disappears automatically. if you want to see errors code you should look Menu 5 - ERROR that is show error codes error date and time also when you locate menu 1 - USER you can see all error codes.

PM01-XX record errors in menu "5-ERROR". press the button long for go to "5-ERROR" . First the date of the latest change is shown. PM01-XX keeps last 10 errors record. It displays errors date and type . you can pass to errors date, type and other errors records by press button once

Example 1	
	(05-01) Activating the push-button, the current information code is displayed.
	(05-02) Activating the push-button, Error accur date
	(05-02) Activating the push-button, Error accur Time
	(05-02) Activating the push-button, Error Code please see 7.6 Error codes type

7.6 ERROR code types

Info code	Description
0	No Error
1	GP22 Resonator calibration error
2	GP22 No hits
3	no measurement
4	GP22 TDC Timeout
5	exposed to timeout of cutoff
6	Measurement not reliable
7	There are errors in the function parameters.
8	GP22 Communication Error
9	GP22 No flow
10	GP22 reverse flow
11	temperature sensor cable is broken
12	there is short circuit in Temperature sensor
13	Flash Memory Error
14	Max Flow rate
15	Temperature sensor T1 is outside of measure range
16	Temperature sensor T2 is outside of measure range

7.7 Data Storage

PM01-xx heat meter every day at 00:00 recording to fixed flash memory;

- a) Accumulative Heating Energy
- b) Accumulative Cooling Energy
- c) Accumulative Volume
- d) Total working Time (hours)
- e) Date Time











Also that record month Accumulative Heating Energy, Cooling Energy at every end of months day and that record Accumulative Heating Energy, Cooling Energy and total volume on last month 5,10,15,20,25th days

8. Display functions

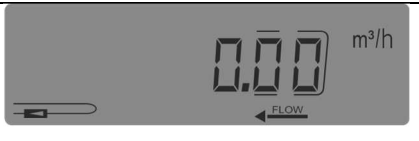
The PM01-XX is equipped easy readable backlight LCD display that include an 8-digit measuring unit and information fields with . The screen turns off unless pressed for 4 minutes and 'backlight' switches off after 20 seconds. When the screen is off, PM01-XX uses 7 different Menu loops : User, Historical, Log, data, Errors, Technical and CAL, Test. It is possible to display only one loop at a time.



8.1 USER MENU

User loop is the primary loop, which is accessible when the meter has been installed and is in normal operation. The loop includes legal and most used readings. User loop is primarily intended for the user of the meter.

01- users menu	01-01 instantaneous heating energy	01-02 instantaneous Cooling energy
		
01-03 Total volume	01-04 Flow Rate	01-05 inlet Temp.(Red one Tin)
		
01-05 Outlet Temp.(blue one Tout)	01-06 Temperature Difference	01-07 Serial manufacturing ID.
		
01-08 Test Display for lost segments		



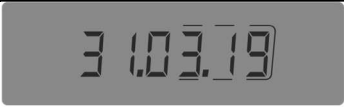

8.2 Historical loop

Historical loop displays the the month average records at last 24 month.

02-00	02-01 end of the months date	02-03 heating energy	02-04 Cooling energy
			









8.3 Log loop



Log loop displays records of 5,10,15,20,25th days of last month.

03-00	03-01 - every loop change the date	03-02 heating energy
		
03-03- cooling energy	03-04- Total volume	
		

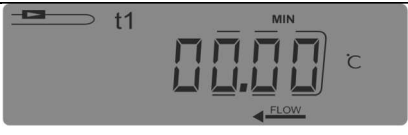
8.4 Data loop

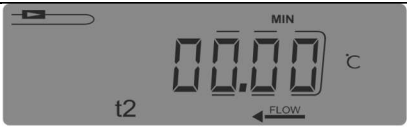
The data loop display the max and min values record of last month.



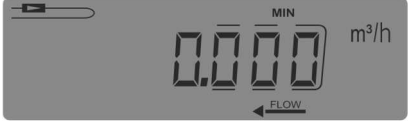



04-00	04-01- working time	04-02 active working time
		
04-03 max instantaneous energy	04-04 min instantaneous energy	04-05 max tin
		
04-06 min tin	04-07 max tout	04-08 min tout
		

04-09 max temp diff	04-10 min temp. diff.	04-11 max flow rate
		
04-12 - min flow rate		
		

8.5 Errors loop

On The Errors loop you can see the last error info codes. For more detail see paragraphe 7.5

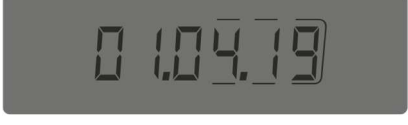
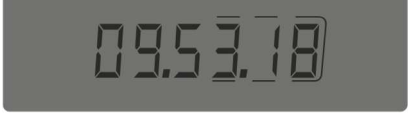
8.6 Technical loop

	06-00 : Technical menu; we use this menu for changed to meters option and futures. the menu only for technical person for easy to access to meters parameters. the menu hidden after installation 24 hours later
	06-01: it as shown meters options 01- : outlet , 00: inlet -01- : Meters units 03 : Meter modes
	06-02: Please see 8.7.2 Changing the energy unit
	06-03: Please see 8.7.1 Changing the installation position
	06-04: Meters modes please see 7.1 Measuring sequences
	06-05: Current Date
	06-06: Current Time
	06-07: Software Reset that is only reset meter hardware setting

8.6.1 Changing the installation position

The setup of the meter's installation position can be changed from inlet meter to outlet meter (and vice versa):



Tech loop

When the meter is in operation TECH loop can be selected by breaking the seal and using the short-circuit pen to make a brief short-circuit, which makes the reading shown to the left appear.

Do not forget to seal with a void label.



Inlet

If the meter is set to be an inlet meter, the text "inlet" is displayed. In order to change the setting, press the button for long. "TECH" is briefly displayed and then "Inlet" flashes. Press the button once and "Outlet" is displayed. If you want to save the setting, press the button for two seconds until "OK" appears in the display.



Outlet

If the meter is set to be an outlet meter, the text "Outlet" is displayed. In order to change the setting, press the button for long. "TECH" is briefly displayed and then "Outlet" flashes. Press the button once and "Inlet" is displayed. If you want to save the setting, press the button for two seconds until "OK" appears in the display.

8.6.2 Changing the energy unit



If you change the energy unit setting in TECH loop you must be aware that the change can influence the most significant digits of the display. If for instance you change from GJ with 2 decimals to GJ with 3 decimals, the most significant digit will disappear. The same applies if you change from kWh without decimals to kWh with 1 decimal. And conversely the least significant digit disappears if e.g. you change from kWh with 1 decimal to kWh without decimals. See examples below:

Example 1



GJ with 2 decimals

This is an example of how the energy reading E1 can appear – counted in GJ.

Example 2



GJ with 3 decimals

Here the most significant digit has disappeared compared to example 1. In outlet you receive a higher resolution.

Example 3



kWh without decimals

This is an example of how energy reading E1 can appear – counted in kWh.

Example 4



kWh with 1 decimal

Here the most significant digit has disappeared compared to example 3. In outlet you receive a higher resolution.

Example 5



MWh with 3 decimals

In principle this is the same resolution as in example 3, but energy is now counted in MWh.

CODE	ACK	SAMPLE
0: U_KWH_0P	kWh no fraction	00001234 kwh
1: U_KWH_1P	kWh 1 point fraction	0000123,4 kwh
2: U_GJ_2P	GJ 2 point fraction	000012,34 GJ
3: U_GJ_3P	GJ 3 point fraction	00001,234 GJ
4: U_MWH_3P	MWh 3 point fraction	00001,234 MWh

8.8 TEST loop

The Test mode gives a high accuracy measurement results during the verification test time. on this mode accuracy for energy shown as 0.001 precision and for volume results as 0.001. Users can pass to the Test mode by long press button in menu 06-04 or use meter tools software or by press button in Test menu. When user gets in Test menu, meter switch to the Test mode automatically and when change the menu meter return back to the next menu.

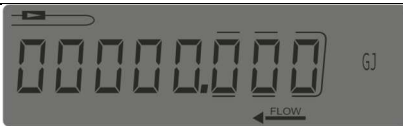
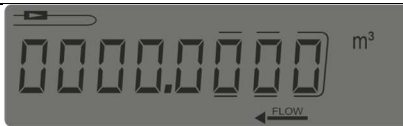
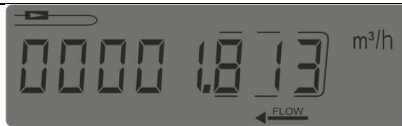
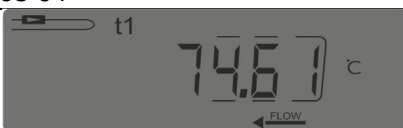
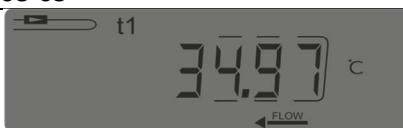
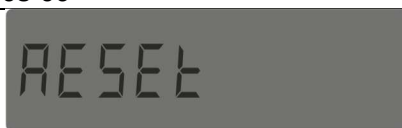

08-01 	08-02 	08-03 
08-04 	08-05 	08-06 
08-07	08-08	

9 Flow sensor

9.1 Ultrasonic heat meters

Simple mechanical structures, low pressure losses, easy installation, low cost, lack of moving mechanical components and high accuracy are the main advantages of ultrasonic heat meters. Experience with ultrasonic meters in operation as well as repeated reliability tests carried out in FNF's accredited long-term test equipment and in Turkey have documented the long-term stability of ultrasonic meters.

9.2 Principles

There are two main principles of ultrasonic flow measuring : the transit time method and the Doppler method. Both are designed to clamp onto the outside of the pipe without breaking the line or interrupting the flow. This also eliminates pressure losses and prevents leaking, which is common with an in-line flow meter. In addition, the flow meter does not come in contact with the liquid, thereby preventing corrosion or deterioration of the sensors. The Doppler and transit time flow meters operate on a similar principle, but the technology varies significantly.

9.3 Transient time method

Transit time ultrasonic flow meters measure the difference in time from when an ultrasonic signal is transmitted from the first transducer until it crosses the pipe and is received by the second transducer. A comparison is made of upstream and downstream measurements. If there is no flow, the travel time will be the same in both directions. When flow is present, sound moves faster if traveling in the same direction and slower if moving against it. Since the ultrasonic signal must traverse the pipe to be received by the sensor, the liquid cannot be comprised of a significant amount of solids or bubbles, or the high frequency sound will be abated and too weak to travel across the pipe.

The difference in the upstream and downstream measurements taken over the same path is used to calculate the flow through the pipe.

Therefore, the time difference is measured as a phase difference between the two 1 MHz sound signals in order to obtain the necessary accuracy.

In principle, the flow is determined by measuring the flow velocity and multiplying it by the area of the measuring pipe:

$$Q = F \times A$$

where: Q is the flow

F is the flow velocity

A is the area of the measuring pipe

The area and the length, which the signal travels in the sensor, are well-known factors. The length which the signal travels can be expressed by $L = T \times V$, which can also be written as:

$$T = \frac{L}{V}$$

where: L is the measuring distance

V is the sound propagation velocity

T is the time

$$\Delta T = L \times \left(\frac{1}{V_1} - \frac{1}{V_2} \right)$$

In connection with ultrasonic flow sensors the velocities V_1 and V_2 can be stated as:

$$V_1 = C - F \text{ and } V_2 = C + F \text{ respectively}$$

where: C is the velocity of sound in water

Using the above formula you get:

$\Delta T=Lx$	$\frac{1}{C-F}$	-	$\frac{1}{C+F}$
which can also be written as:			

$$\Delta T=Lx \frac{(C+F)-(C-F)}{(C-F)-(C+F)}$$

↓

$$\Delta T=Lx \frac{2F}{C^2-F^2}$$

As $C \gg F - F^2$ can be omitted and the formula reduced as follows:

$$F = \frac{\Delta T \times C^2}{L \times 2}$$

9.4 Signal paths

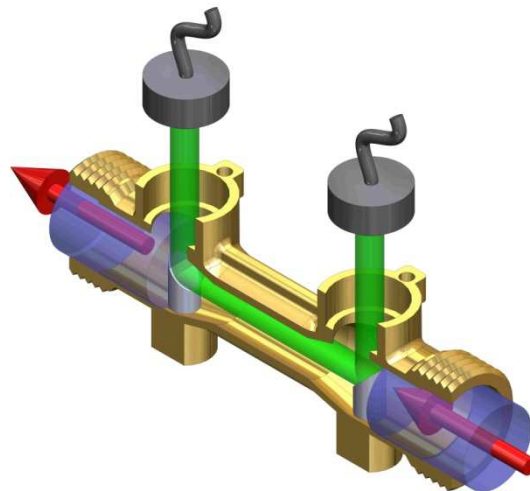

qp 0.6 - 1.5 - 2.5 m³/h

Parallel measurement

The sound path is parallel to the measuring pipe and the sound signal is sent from the transducers via reflectors.

9.5 Flow limits

In the meter's working range from min. flow cutoff and far beyond q_s there is a linear connection between the flow rate and the measured water flow.

In practice the highest possible water flow through the meter will be limited by the pressure in the system or possible cavitation due to too low back pressure.

If the flow is lower than min. cutoff or negative, PM01-XX does not measure any flow.

According to EN 1434 the upper flow limit q_s is the highest flow at which the flow sensor may operate for short periods of time (<1h/day, <200h/year) without exceeding max. permissible errors. PM01 has no functional limitations during the period, when the meter operates above q_p . Please note, however, that high flow velocities may cause cavitation, especially at low static pressure. See paragraph 6.5 for further details on operating pressure.

9.6 Flow Sensor Data

Manufacturer	FNF
Type	PM01-XX
Accuracy class	Class 2
Limits of flow-rate (q_i , q_p and q_s):m ³	DN-15: q_i :0,006m ³ /h, q_p :0,6 m ³ /h, q_s :1,2m ³ /h DN-15: q_i :0,015m ³ /h, q_p :1,5 m ³ /h, q_s :3 m ³ /h DN-20: q_i :0,025 m ³ /h, q_p :2,5 m ³ /h, q_s :5 m ³ /h DN-25: q_i :0,035 m ³ /h, q_p :3,5 m ³ /h, q_s :7 m ³ /h DN-32: q_i :0,60m ³ /h, q_p :6 m ³ /h, q_s :12 m ³ /h DN-40: q_i :0,1m ³ /h, q_p :10 m ³ /h, q_s :20 m ³ /h
PS/PN (bar)	16
Flow sensor type	Not long life type
Max Pressure loss at q_p	≤25kPa
Max admissible temperature	90°C
Limits of temperature (Θ_{min} and Θ_{max})	5~90°C 2~50°C

Mounting	Straight sections of 10×DN before and 5×DN after the meter
Nominal meter factor	N/A
Installation requirements	Min. 10*DN length of straight pipe before the meter, and Min. 5*DN length of straight pipe after the meter (DN is the diameter of meter)
Basic mounting orientation and other specified orientations	Vertical / Horizontal
Pulse output device class	OC
Output signal for testing	N/A
Output signal for testing(type/levels)	N/A

Low flow threshold value (m ³ /h)	DN15/20/25:0.02, DN32/40
Liquid if other than water	N/A
Response time-for fast response meter	N/A
Mains power supply requirements	N/A
Battery power requirements	3.6V
Nominal voltage level for external power supply	N/A

10 Temperature sensors

PM01-XX has wet and dry type temperature sensor. Each type can be produced by customer request. PM01-XX comes with fixed (soldered) Pt1000 temperature sensors according to EN 60751 (DIN/IEC 751). A Pt1000 temperature sensor is a platinum sensor that has a nominal ohmic resistance of 1000 Ω at 0.00 $^{\circ}\text{C}$ and 1385,055 Ω at 100.00 $^{\circ}\text{C}$. All ohmic resistance values are laid down in the international standard IEC 751 applying to Pt100 temperature sensors. The ohmic resistance values of Pt1000 sensors are five times higher. The table below shows resistance values of Pt1000 sensors in [Ω] for each degree Celsius:

	+0 $^{\circ}\text{C}$	+1 $^{\circ}\text{C}$	+2 $^{\circ}\text{C}$	+3 $^{\circ}\text{C}$	+4 $^{\circ}\text{C}$	+5 $^{\circ}\text{C}$	+6 $^{\circ}\text{C}$	+7 $^{\circ}\text{C}$	+8 $^{\circ}\text{C}$	+9 $^{\circ}\text{C}$	+10 $^{\circ}\text{C}$
0	1000	1003,908	1007,814	1011,72	1015,624	1019,527	1023,429	1027,33	1031,229	1035,128	1039,025
10	1039,025	1042,921	1046,816	1050,71	1054,603	1058,495	1062,385	1066,274	1070,162	1074,049	1077,935
20	1077,935	1081,82	1085,703	1089,585	1093,467	1097,347	1101,225	1105,103	1108,98	1112,855	1116,729
30	1116,729	1120,602	1124,474	1128,345	1132,215	1136,083	1139,95	1143,817	1147,681	1151,545	1155,408
40	1155,408	1159,27	1163,13	1166,989	1170,847	1174,704	1178,56	1182,414	1186,268	1190,12	1193,971
50	1193,971	1197,821	1201,67	1205,518	1209,364	1213,21	1217,054	1220,897	1224,739	1228,579	1232,419
60	1232,419	1236,257	1240,095	1243,931	1247,766	1251,6	1255,432	1259,264	1263,094	1266,923	1270,751
70	1270,751	1274,578	1278,404	1282,228	1286,052	1289,874	1293,695	1297,515	1301,334	1305,152	1308,968
80	1308,968	1312,783	1316,597	1320,411	1324,222	1328,033	1331,843	1335,651	1339,458	1343,264	1347,069
90	1347,069	1350,873	1354,676	1358,477	1362,277	1366,077	1369,875	1373,671	1377,467	1381,262	1385,055
100	1385,055	1388,847	1392,638	1396,428	1400,217	1404,005	1407,791	1411,576	1415,36	1419,143	1422,925
110	1422,925	1426,706	1430,485	1434,264	1438,041	1441,817	1445,592	1449,366	1453,138	1456,91	1460,68
120	1460,68	1464,449	1468,217	1471,984	1475,75	1479,514	1483,277	1487,04	1490,801	1494,561	1498,319
130	1498,319	1502,077	1505,833	1509,589	1513,343	1517,096	1520,847	1524,598	1528,347	1532,096	1535,843
140	1535,843	1539,589	1543,334	1547,078	1550,82	1554,562	1558,302	1562,041	1565,779	1569,516	1573,251
150	1573,251	1576,986	1580,719	1584,451	1588,182	1591,912	1595,641	1599,368	1603,095	1606,82	1610,544
160	1610,544	1614,267	1617,989	1621,709	1625,429	1629,147	1632,864	1636,58	1640,295	1644,009	1647,721

Table 5

10.1 Temperature sensor data

PM01-XX uses two different brands temperature sensors :

Manufacturer	JUMO
Type	JUMO (902485/10/1500)
Temperature range	0~105°C
Temperature difference range	3~75K 3~30K
Maximum admissible working pressure(PS in bar)	25
Cable lenght	1500mm
Maximum admissible temperature	105°C
Wiring of sensors	2-wire
Principle of operation	Precise Platinum resistor's resistance varied with the temperature
Maximum RMS value of sensor current	5 Ua
Physical dimensions	see the data sheet of the temperature sensor.
Installation requirement	Direct mounting
Maximum liquid velocity for sensor over 200 mm length (m/s)	2m/s
Total resistance of a 2-wire cable	1000 ohm
Output signal for rated operation	External Resistance
Response time	2s with 50% temperature varies
Protecting case	Stainless Steel diameter=5mm
RTD	Pt1000
Qualifying immersion depth for temperature sensors	15mm
Manufacturer	BOCON
Type	TM1101-5-1500
Temperature range	0~105°C
Temperature difference range	3~ 75K 3~ 30K
Maximum admissible working pressure(PS in bar)	25
Cable lenght	1500mm

Maximum admissible temperature	105°C
Wiring of sensors	2-wire
Principle of operation	Precise Platinum resistor's resistance varied with the temperature
Maximum RMS value of sensor current	5 Ua
Physical dimensions	see the data sheet of the temperature sensor.
Maximum liquid velocity for sensor over 200 mm length (m/s)	2m/s
Total resistance of a 2-wire cable	1000 ohm
Output signal for rated operation	External Resistance
Response time	2s with 50% temperature varies
Protecting case	Stainless Steel diameter=5mm
RTD	Pt1000
Min. immersion depth for temperature sensors	20mm

10.2 Sensor types

PM01-XX has Wet and dry type temperature sensor. For wet type PM01-XX comes with a Ø5.2 mm Pt1000 temperature sensor pair fitted with brass couplings and 1.5 m silicone cable. The composite coupling is made of PPS and withstands a maximum continuous temperature of 150 °C and may be used together with both PN16 and PN25. By means of the fitted composite couplings and associated O-rings, the temperature sensor pair is used as direct temperature sensors.

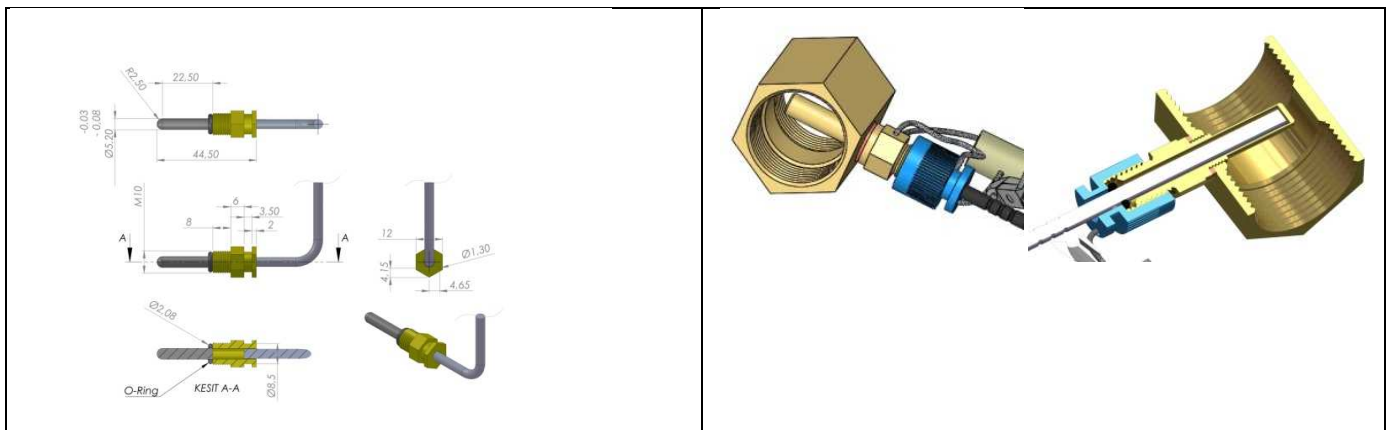

Wet type

Dry type

At delivery, one of the temperature sensors is always mounted in the flow sensor and the other temperature sensor must thus be mounted as a direct temperature sensor in, for example, a ball valve or a nipple. No matter where the direct sensor is installed, it is very important that you observe the tolerances stated in Figure Y. If not, the O-ring may not provide correct sealing. If one of the temperature sensors is not to be mounted in the flow sensor, this sensor must instead be mounted as close to the outlet of the flow sensor as possible so that the distance between the flow sensor and the temperature sensor is max 12 cm.

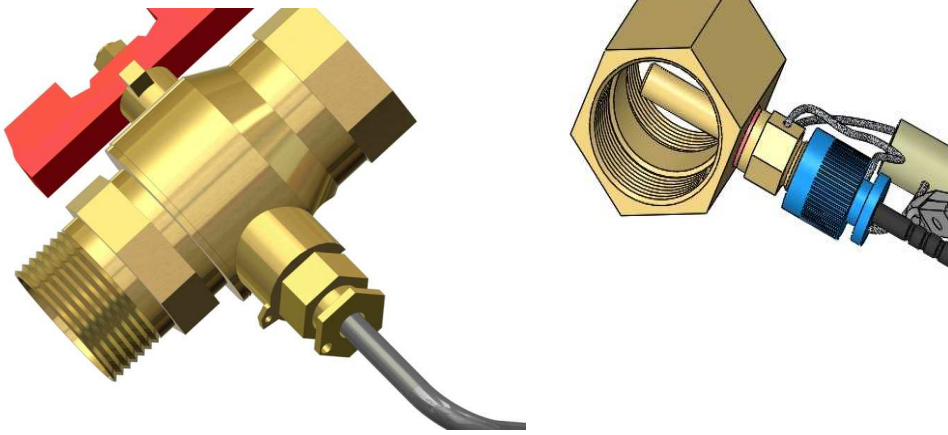

Fasten the plastic coupling manually. The use of tools is not permitted.

10.4 Using temperature sensors as pocket sensors

If the temperature sensors are to be used as pocket sensors, the temperature sensor mounted in the sensor socket of the flow sensor is first removed. Note that the O-ring of the temperature sensor is also removed. As shown in the figure below, a blind plug is then inserted in the sensor socket.

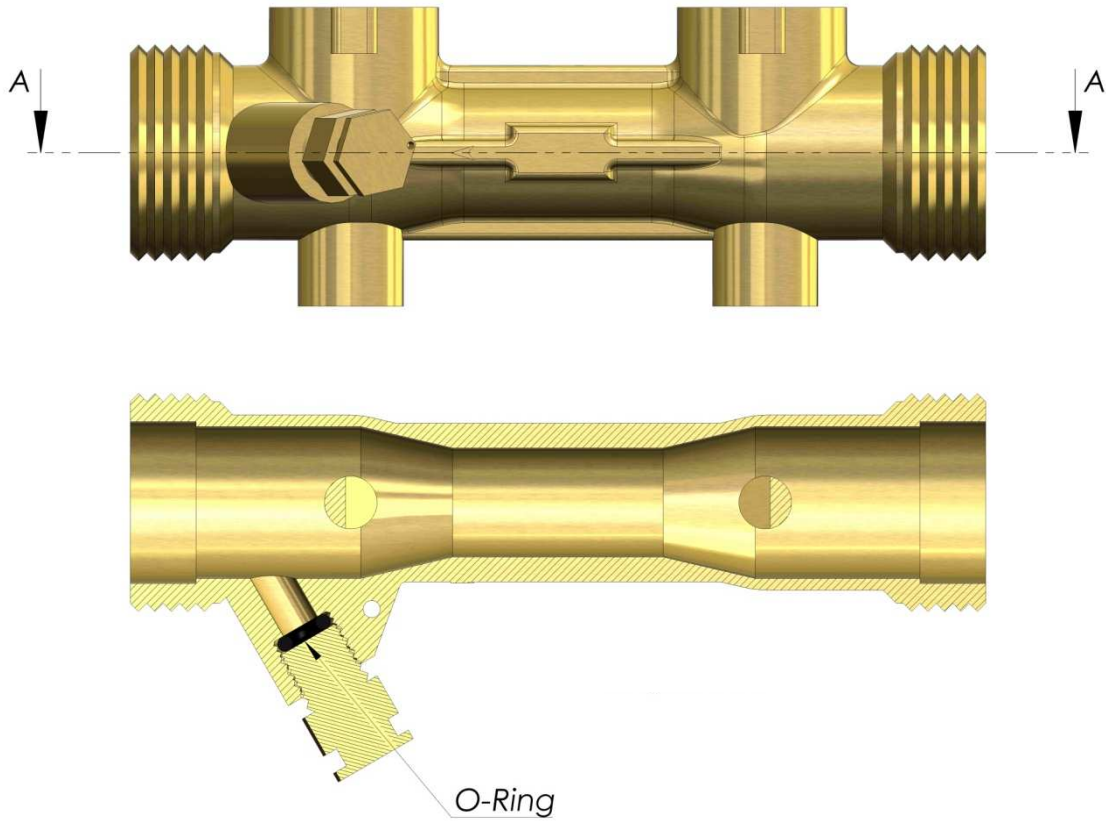

11. Built-in A-cell lithium battery

The A-cell lithium battery is sufficient to power PM01-XX for a 5 - 7-year period of operation. A-cell lithium batteries include 0.96 g lithium and are thus not subject to transport restrictions.

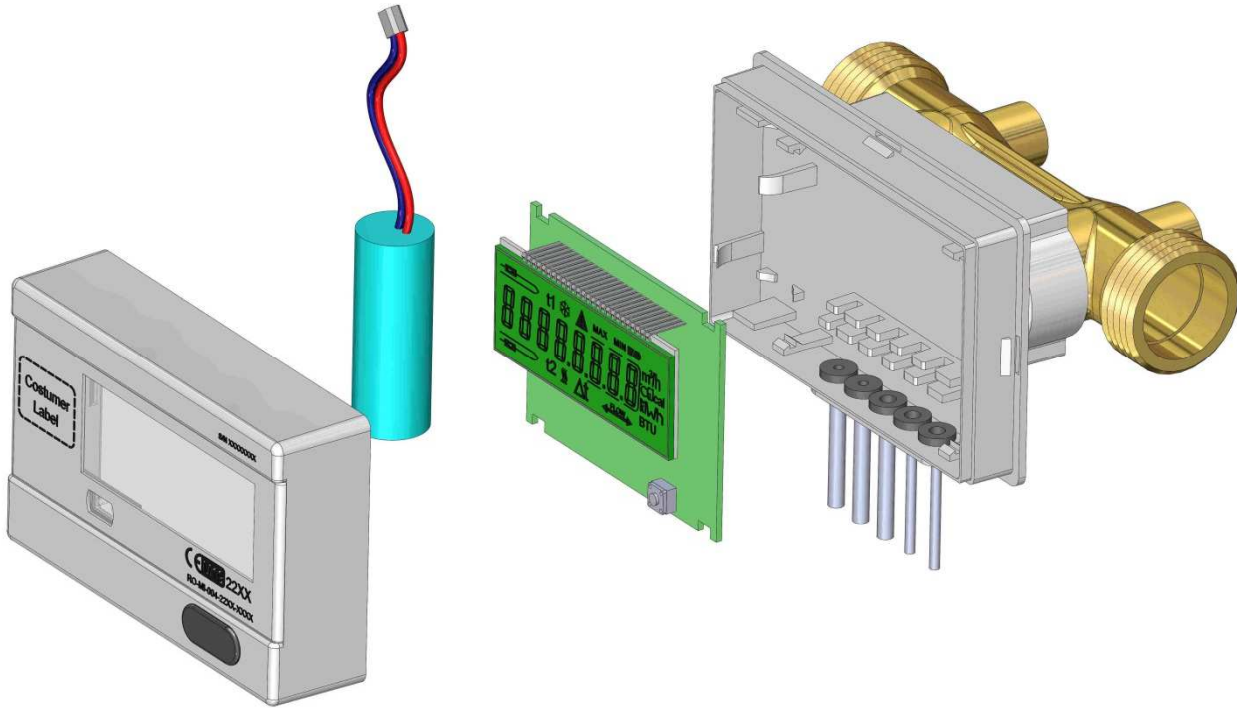

Note: PM01 cannot be mains supplied.

12 Communication

PM01-XX offers two different forms of communication, namely wired M-Bus or Wireless M-Bus. or Lora communication

12.1 Wired M-Bus

Cable: connected with galvanic

isolation Voltage: 50V max.

Current: M-Bus loads

Addressing: primary or secondary

Note: A higher frequency is not allowed and may result in meter malfunction!

Data transmission in the compatibility mode (= standard, one data frame) or in the full mode (3 data frames) possible.

If the meter is equipped with "M-bus", it is delivered with a two wire cable, which can be lengthened with a cable 2 x 0.75mm² (put a distributing box). Pay attention to the proper polarity in case of the pulse output. If the meter is read out via M-bus, the allowed mean frequency of reading must not be exceeded. Any more reading is not allowed and may result in a damage to meter.

12.2 Sample Telegram long frame for M-bus Communication:

```
0x68, 0x57, 0x57, 0x68, /* 0 */
    0x08, /* 4, C Field */
    sID1, /* 5, A Field */
    0x72, /* 6, CI Field */
    /* User Data */
    sID2[3], sID2[2], sID2[1], sID2[0], /* 7 "12345678" */
    0xC6, 0x19, /* 11, 0X19C6 = 6598 FNF MANUFACTURE CODE */
    0x01, 0x04, 0x03, 0x00, 0x00, 0x00, /* 13 */
    /*-----*/
    0x0C, /* 19, DIF 4 BYTE BCD */
    0x06, /* 20, VIF WH * 1000 */
    0, 0, 0, 0, /* 21, fToBCD(kwh_hot * 1000); */
    /*-----*/
    0x0C, /* 25, DIF */
```

0x13, /* 26, VIF M3 */
0, 0, 0, 0, /* 27, fToBCD(m3); */
/*-----*/
0x0C, /* 31, DIF */
0x22, /* 32, VIF */
0, 0, 0, 0, /* 33, fToBCD(WorkHours); */
/*-----*/
0x0C, /* 37, DIF */
0x2E, /* 38, VIF */
0, 0, 0, 0, /* 39, fToBCD(kwh_cold * 1000); */
/*-----*/
0x0C, /* 43, DIF */
0x3B, /* 44, VIF */
0, 0, 0, 0, /* 45, fToBCD(m3h); */
/*-----*/
0x0A, /* 49, DIF */
0x59, /* 50, VIF */
0, 0, /* 51, fToBCD(tin * 100); */
/*-----*/
0x0A, /* 53, DIF */
0x5D, /* 54, VIF */
0, 0, /* 55, fToBCD(tout * 100); */
/*-----*/
0x0A, /* 57, DIF */
0x61, /* 58, VIF */
0, 0, /* 59, fToBCD(tfark * 100/-100); */
/*-----*/
0x42, /* 61, DIF */
0x6C, /* 62, VIF */
0, 0, /* 63,
/*-----*/

```
0xCC, /* 65, DIF it has DIFE and Stroge value */
0x41, /* 66, DIFE Storage number:1;tariff:0 device unit :1 */
0x06, /* 67, VIF WH * 1000 */
0, 0, 0, 0, /* 68, logHOT[time.ui8Month - 1] */
/*-----*/
0xCC, /* 72, DIF it has DIFE and Stroge value */
0x41, /* 73, DIFE Storage number:1;tariff:0 device unit :1 */
0x06, /* 74, VIF WH * 1000 */
0, 0, 0, 0, /* 75, logHOT[time.ui8Month - 2] */
/*-----*/
0x0C, /* 79, DIF 4 BYTE BCD */
0x0E, /* 80, VIF GJ = kwh * 3.6e6 */
0, 0, 0, 0, /* 81, fToBCD(kwh_hot * 3.6);*/
/*-----*/
0x0C, /* 85, DIF 4 BYTE BCD */
0x0E, /* 86, VIF GJ = kwh * 3.6e6 */
0, 0, 0, 0, /* 87, fToBCD(kwh_cold * 3.6);*/
/* ----- */
0, /* 91, CRC */
0x16 // stop bit
```

13. Meter Tools Software

The screenshot displays the 'poli meter' software interface. On the left, there is a vertical sidebar with five sticky-note-like buttons: 'Meter Params' (teal), 'Verification' (orange), 'Calibration' (green), 'Exit' (black), and an unlabeled purple button. The main interface is divided into several sections:

- Primary Address:** A text box containing '254' with a 'Set primary address' button (red dot icon).
- Secondary Address:** A text box containing '12345678' with a 'Set Date/time' button (calendar icon) and a 'Set secondary address' button (yellow bell icon).
- Constant temp. pools:** Two text boxes for 'TEMP COLD' and 'TEMP HOT', both set to '15.00 °C'. A 'Calibrate Temp Sensors' button (green checkmark icon) is present, along with a 'CLEAR TO Calibration Values' button (yellow warning icon).
- Meters Configuration Values:** A table with two columns. The left column lists configuration items, and the right column shows their current values.

Meter Working Mode	1. Transport Mode
Installation Type	2. OUTLET (Return)
Meter Unit	KWH No Fragtion
Setup Menu	Active
Qhc & Qch values °C	30 °C 30 °C
K: Δθmin heating & Δθmax cooling	3 °C 1 °C
- Calibrations Values:** A table with two columns. The left column lists calibration values, and the right column shows their current values.

1. Calibration Value (50lt)	1000
2. Calibration Value	1000
3. Calibration Value	1000
4. Calibration Value	1000
5. Calibration Value	1000
6. Calibration Value(2500lt)	1000

At the bottom of the configuration and calibration sections, there are 'Sent Meter Params' and 'Sent to Calibration Values' buttons, respectively.

FNF Teknoloji AŞ.
 For the attention of: Quality and environmental dept.
 Tel: +90 352 333 2525
 Fax: +90 352 333 2526
 info@polimeter.com